

an ISO9001/14001 company

Technical Information for Carbon Monoxide Sensors

The Figaro TGS2442 sensor is a new type thick film metal oxide semiconductor, screen printed sensor which offers miniaturization and utilizes pulse heating for achieving low power consumption. The TGS2442 displays high selectivity to carbon monoxide together with improved humidity dependency and durability.



<i>Basic Information and Specifications</i>	<i>Page</i>
Features.....	2
Applications.....	2
Structure.....	2
Basic Measuring Circuit.....	2
Circuit & Operating Conditions.....	3
Mechanical Strength.....	3
Dimensions.....	3
<i>Operation Principle</i>	4
<i>Typical Sensitivity Characteristics</i>	
Sensitivity to Various Gases.....	5
Temperature and Humidity Dependency.....	5
Gas Response Pattern.....	6
Heater Voltage Dependency.....	6
Initial Action.....	7
Influence of Unenergized Storage.....	7
<i>Reliability</i>	
Interference Gas Test.....	8
Long-Term Stability.....	9
Corrosion Test.....	9
Variable Ambient Temperature Test.....	9
Humidity Test.....	10
Stability Tests.....	10
<i>Circuit Examples</i>	
Basic Circuit Including Trouble Detection.....	11
Calibration and Temperature Compensation.....	11
<i>Marking and Packaging</i>	13
<i>See also Technical Brochure "Technical Information on Usage of TGS Gas Sensors for Explosive/Toxic Gas Alarming".</i>	

IMPORTANT NOTE: OPERATING CONDITIONS IN WHICH FIGARO SENSORS ARE USED WILL VARY WITH EACH CUSTOMER'S SPECIFIC APPLICATIONS. FIGARO STRONGLY RECOMMENDS CONSULTING OUR TECHNICAL STAFF BEFORE DEPLOYING FIGARO SENSORS IN YOUR APPLICATION AND, IN PARTICULAR, WHEN CUSTOMER'S TARGET GASES ARE NOT LISTED HEREIN. FIGARO CANNOT ASSUME ANY RESPONSIBILITY FOR ANY USE OF ITS SENSORS IN A PRODUCT OR APPLICATION FOR WHICH SENSOR HAS NOT BEEN SPECIFICALLY TESTED BY FIGARO.



TGS2442 is a UL recognized component in accordance with the requirements of UL2034. Please note that component recognition testing has confirmed long term stability in 15ppm of carbon monoxide; other characteristics shown in this brochure have not been confirmed by UL as part of component recognition.

1. Basic Information and Specifications

1-1 Features

- * Miniature size and low power consumption
- * High sensitivity/selectivity to carbon monoxide (CO)
- * Low sensitivity to alcohol vapor
- * Reduced influence by various interference gases
- * Long life and low cost

1-2 Applications

- * Residential and commercial CO detectors
- * Air quality controllers
- * Ventilation control for indoor parking garages

1-3 Structure

Figure 1 shows the structure of TGS2442. The sensor utilizes a multilayer structure. A glass layer for thermal insulation is printed between a ruthenium oxide (RuO₂) heater and an alumina substrate. A pair of Au electrodes for the heater are formed on a thermal insulator. The gas sensing layer, which is formed of tin dioxide (SnO₂), is printed on an electrical insulation layer which covers the heater. A pair of Pt electrodes for measuring sensor resistance is formed on the electrical insulator. An activated charcoal filter is used for the purpose of reducing the influence of noise gases.

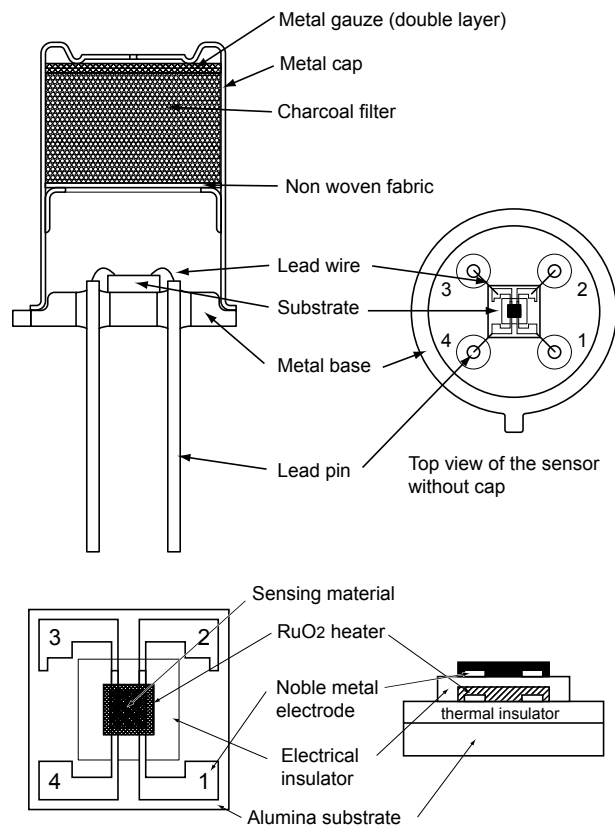

Figure 1 - Sensor structure

1-4 Basic measuring circuit

Figure 2 shows the basic measuring circuit of the TGS2442. Circuit voltage (V_c) is applied across the sensing element which has a resistance (R_s) between the sensor's two electrodes (pins No. 2 and No. 3) and a load resistor (R_L) connected in series. The sensing element is heated by the heater which is connected to pins No. 1 and No. 4.

The sensor requires application of a 1 second heating cycle which is used in connection with a circuit voltage cycle of 1 second. Each V_H cycle is comprised by 4.8V being applied to the heater for the first 14ms, followed by 0V for the remaining 986ms. The V_c cycle consists of 0V applied for 995ms, followed by 5.0V for 5ms. For achieving optimal sensing characteristics, the sensor's signal should be measured after the midpoint of the 5ms V_c pulse of 5.0V (for illustration, see the timing chart in Fig. 3).

NOTE: Application of a V_c pulse condition is required to prevent possible migration of heater materials into the sensing element material. Under extreme conditions of high humidity and temperature, a constant V_c condition could result in such migration and cause long term drift of R_s to higher values. A 5ms V_c pulse results in significantly less driving force for migration than a constant V_c condition, rendering the possibility of migration negligibly small.

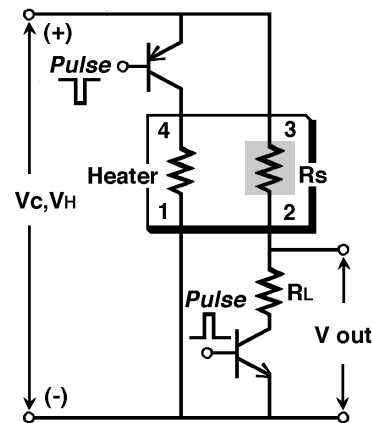

Figure 2 - Basic measuring circuit (including equivalent circuit)

1-5 Circuit & operating conditions

The following conditions should be maintained to ensure stable sensor performance:

Model number		TGS 2442
Sensing element type		M1
Standard package		TO-5 metal can
Target gases		Carbon monoxide
Typical detection range		30 ~ 1000 ppm
Standard circuit conditions	Heater voltage cycle	V _H V _{HH} =4.8V±0.2V DC, 14ms V _{HL} =0.0, 986ms
	Circuit voltage cycle	V _C V _C =0V for 995ms, V _C =5.0V±0.2V DC for 5ms
	Load resistance	R _L variable (≥10kΩ)
Electrical characteristics under standard test conditions	Heater resistance	R _H 17 ± 2.5Ω at room temp.
	Heater current	I _H approx. 203mA(in case of V _{HH})
	Heater power consumption	P _H approx. 14mW (ave.)
	Sensor resistance	R _S 13.3kΩ ~ 133kΩ in 100ppm of carbon monoxide
	Sensitivity (change ratio of R _S)	β 0.13 ~ 0.31
Standard test conditions	Test gas conditions	Carbon monoxide in air at 20±2°C, 65±5%RH
	Circuit conditions	Same as Std. Circuit Condition (above)
	Conditioning period before test	2 days or more

Formula for calculation of sensor resistance:

$$R_s = \frac{V_c \times R_L}{V_{out}} - R_L$$

Sensitivity (change ratio of R_S) is calculated with two measured values of R_S as follows:

$$\beta = \frac{R_s(CO,300ppm)}{R_s(CO,100ppm)}$$

1-6 Mechanical Strength

The sensor shall have no abnormal findings in its structure and shall satisfy the above electrical specifications after the following performance tests:

Withstand Force - withstand force of 5kg in each direction (pin from base)

Vibration - frequency--10-500Hz (equiv. to 10G), duration-6 hours, x-y-z direction

Shock - acceleration-100G, repeat 5

1-7 Dimensions (see Fig. 4)

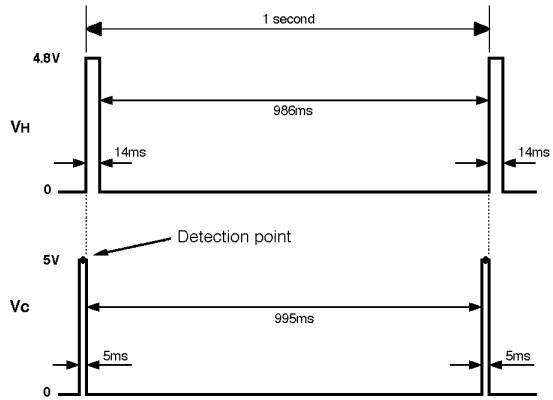

Figure 3 - Circuit voltage and heater voltage cycles

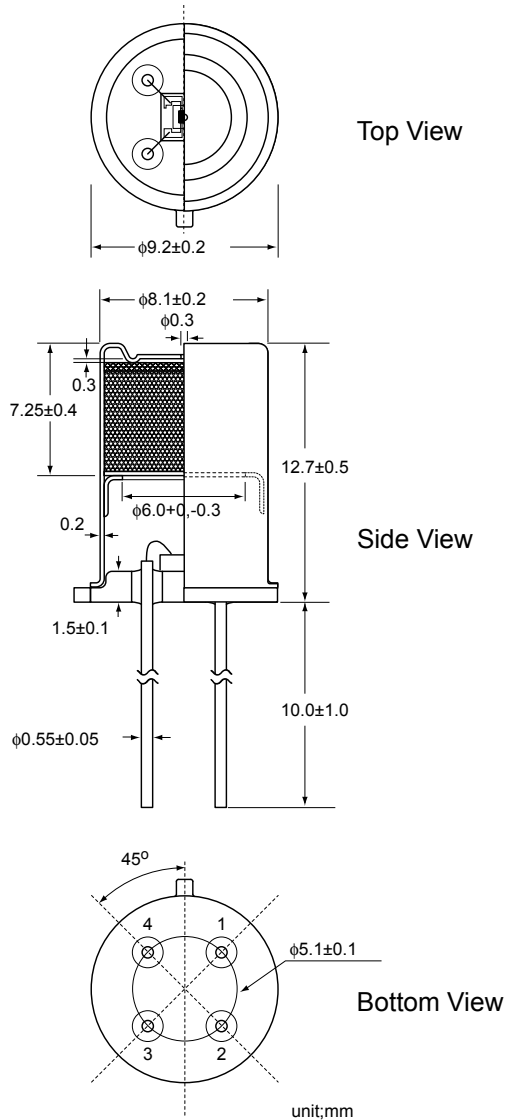

Figure 4 - Dimensions

2. Operation Principle

The optimum conditions of sensitivity and selectivity to CO of the TGS2442 occurs at sensor temperatures less than 100°C. However, at these lower temperatures, the sensing element may be influenced by humidity and other contaminants, so the sensing element requires periodic heat cleaning at more than 300°C. As a result, the TGS2442 is pulse heated to achieve optimal sensing characteristics at low temperatures.

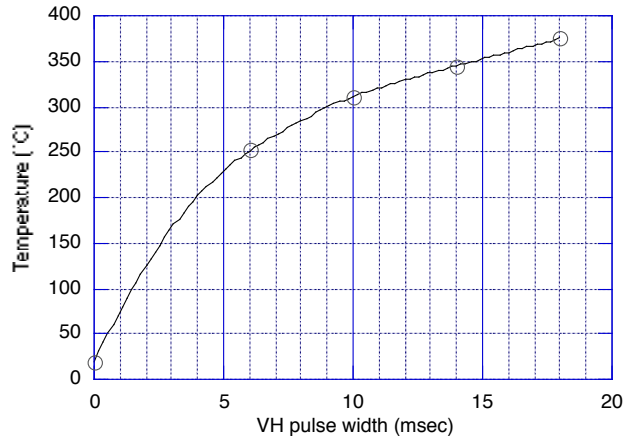

Figure 5 - Relationship of sensor temperature and VH pulse width (VH=4.8V, RH=17%)

Figure 6a shows the pattern of resistance change ratio (R_s/R_o) for various CO concentrations which occurs during the 1 second heater pulse cycle, starting with application of the 14ms VH pulse. During the VH pulse, initially sensor resistance drops quickly and then returns to a higher value. After the VH pulse concludes and the sensing element's surface temperature begins to decrease (Fig. 6b), sensor resistance reaches to its maximum value and then begins to decline. Note that the shape of the response pattern varies according to the concentration of CO--higher CO concentrations result in a minimum R_s/R_o value which occurs more quickly and has a lower value. In addition, shortly after the VH pulse, the R_s/R_o value also trends downwards at a greater rate for higher CO concentrations after reaching its maximum value.

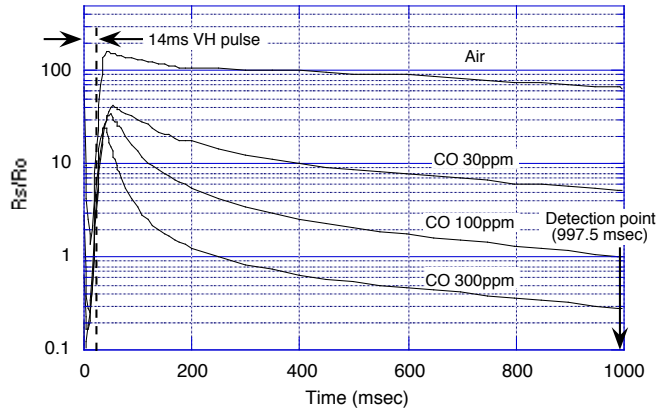

Figure 6a - Sensitivity characteristics during the VH pulse cycle (Ro = Rs in 100ppm CO at 997.5ms of VH cycle)

A signal detection point of 997.5ms into the VH pulse cycle (ref. timing chart in Fig. 3) is used to obtain the optimum combination of gas sensitivity performance and minimized ambient humidity effect.

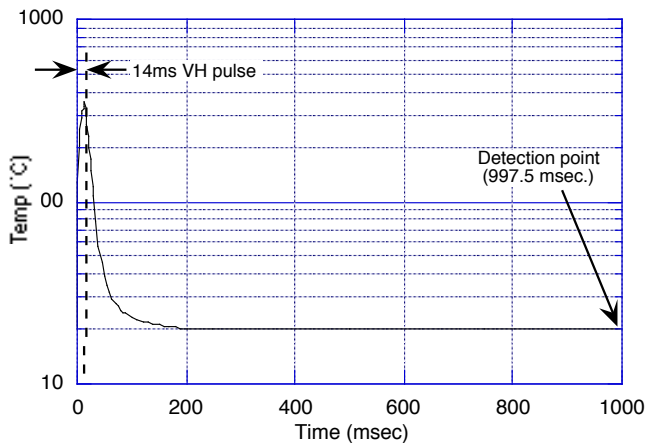

Figure 6b - Surface temperature of sensing element during VH pulse cycle (0msec = start of VH pulse cycle)

All sensor characteristics shown in this brochure represent typical characteristics. Actual characteristics vary from sensor to sensor and from production lot to production lot. The only characteristics warranted are those shown in the Specification on Page 3.

3. Typical Sensitivity Characteristics

3-1 Sensitivity to various gases

Figure 7 shows the sensor's relative sensitivity to various gases. The Y-axis shows the ratio of sensor resistance in various gases (R_s) to the sensor resistance in 100ppm of CO (R_o).

As shown by Figure 7, TGS2442 shows very good sensitivity to CO since the sensitivity curve to CO shows a sharp drop in sensor resistance as CO concentration increases. In comparison, sensitivity to ethanol (C_2H_5OH) is very low as evidenced by the relatively flat slope of its sensitivity curve and high resistance values.

The amount of CO generated by cigarette smoke is roughly equivalent to 20ppm of CO when 10 cigarettes are smoked in a room of roughly 24 cubic meters in size. As a result, the influence of cigarette smoke itself would not be sufficient to cause the sensor to generate an alarm for residential detectors using TGS2442 which are normally calibrated to alarm at 100ppm of CO.

3-2 Temperature and humidity dependency

Figure 8a shows the temperature dependency of TGS2442. The Y-axis shows the ratio of sensor resistance for various CO concentrations under various temperature conditions (R_s) to the sensor resistance in 100ppm of CO at 50%RH (R_o).

Figure 8b shows the humidity dependency of TGS2442. The Y-axis shows the ratio of sensor resistance for various CO concentrations under various relative humidity conditions (R_s) to the sensor resistance in 100ppm of CO at 20°C.

An inexpensive way to compensate for temperature dependency to a certain extent would be to incorporate a thermistor in the detection circuit (please refer to Section 5-2).

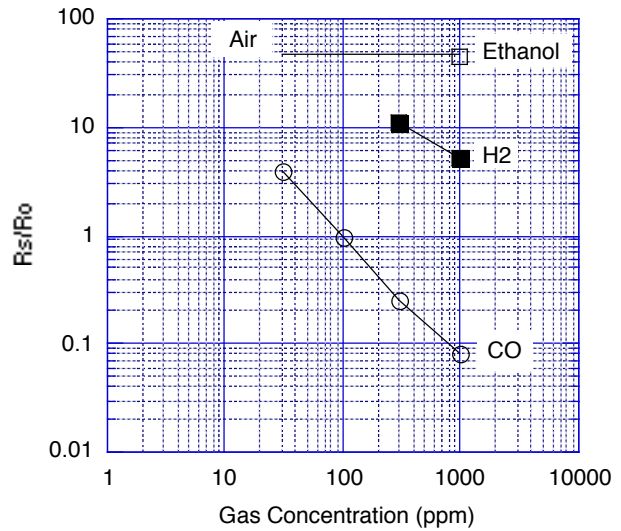

Figure 7 - Sensitivity to various gases ($R_o = R_s$ in 100ppm of CO)

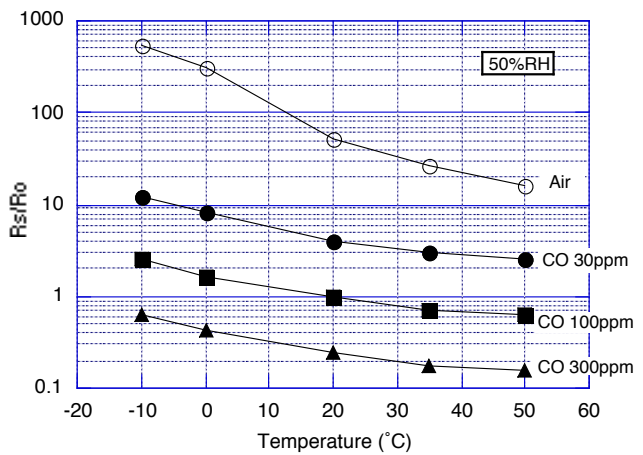

Figure 8a - Temperature dependency at 50%RH ($R_o = R_s$ in 100ppm of CO at 20°C)

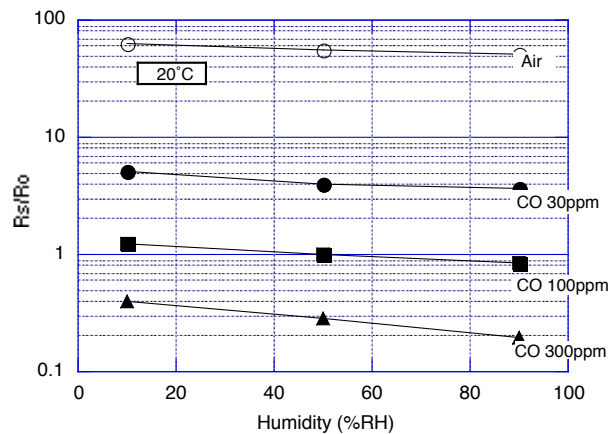

Figure 8b - Humidity dependency at 20°C ($R_o = R_s$ in 100ppm of CO at 50%RH)

3-3 Gas response pattern

The response pattern of the TGS2442 sensor is similar to that of a constant VH sensor since data acquisition is carried out once every second during operation. Figure 9 shows the pattern of the output signal when the sensor is placed into 70, 150, and 400ppm of CO and then returned to normal air. The response time to 90% of the saturated signal level is roughly 3.3 minutes and the recovery of the sensor to 90% of the base level is within 10 minutes. This data demonstrates that TGS2442 possesses sufficient response speed for meeting UL requirements for CO detectors.

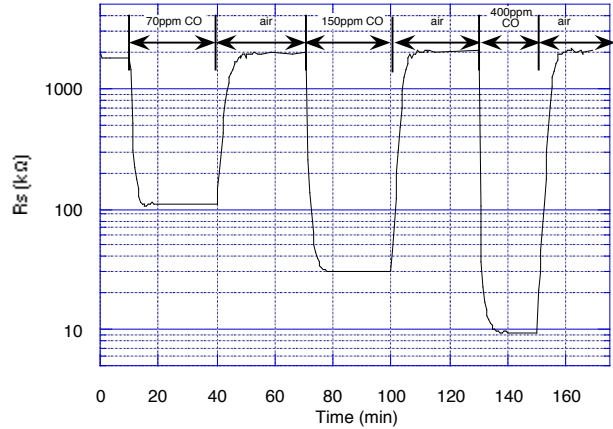

Figure 9 - TGS2442 response pattern in 70, 150, and 400ppm CO

3-4 Heater voltage dependency

The TGS2442 should be used with a heater voltage of $4.8 \pm 0.2V$. Although at the detection point the sensor's temperature is close to room temperature, its gas sensing characteristics are affected by heater voltage as can be seen in Figure 10. At lower heater voltage, the R_s/R_o decreases and the difference in sensitivity between CO concentrations narrows. If heater voltages is higher, sensor resistance increases.

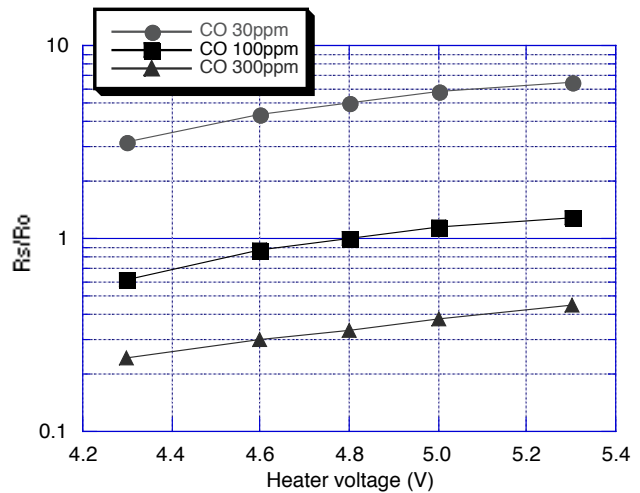

Figure 10 - Heater voltage dependency
($R_o = R_s$ at 100ppm of CO and $V_H=4.8V$)

3-5 Initial action

Figure 11 shows the initial action of the sensor's resistance. For purposes of this test, the sensor was stored unenergized in normal air for 40 days after which it was energized in clean air.

After energizing, the sensor's resistance reaches to 90% of its final value in less than one minute, an alarm delay circuit should be incorporated into detectors using TGS2442 to prevent activation of an alarm during this period.

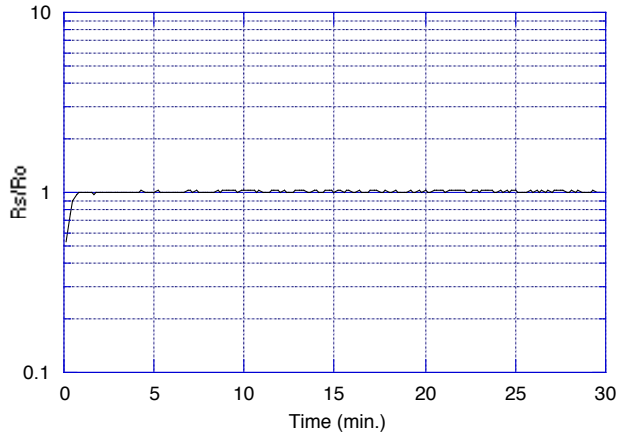

Figure 11 - Initial action
(Ro = Rs after 20 minutes of energizing)

3-6 Influence of unenergized storage

Figure 12 shows the influence of unenergized storage on sensor resistance. Sensors were stored unenergized in normal air for 30 days after which they were energized. The Y-axis represents the ratio of sensor resistance in various concentrations of CO after the unenergized period (Rs) to the resistance in 100ppm of CO after energizing at the rated voltage for 4 days (Ro).

This chart shows that after energizing, unlike the sensor resistance in clean air (as shown in Fig. 11), resistance in CO first decreases slightly and then returns to a stable level, demonstrating the need for adhering to the recommended preheating period prior to calibration.

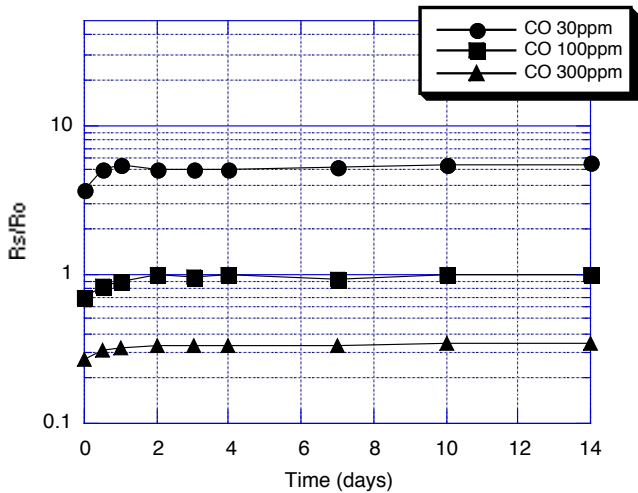

Figure 12 - Time dependency
(Ro = Rs in 100ppm of CO after 4 days, n=20)

4. Reliability

Tests conducted in this section demonstrate that TGS2442 can meet the requirements of various testing standards without incurring adverse long term effects from such tests.

4-1 Interference gas test

Figure 13 shows the results of testing the TGS2442 sensor for durability against various interference gases specified by GRI Test Protocol 1. The test was conducted by exposing the sensor to each gas shown in Fig. 13 (starting with CO 100ppm) for two hours, then removing the sensor to fresh air for just under one hour, and followed by inserting the sensor into the next test gas. This procedure was repeated for the full range of gases shown in Fig. 13.

Because the sensor is exposed to each of the test gases consecutively, to some small extent the effect of the previous test gas may affect subsequent tests for a short period. However, despite the short-term effects of such gases remaining after exposure, the sensor still shows significantly less sensitivity to each test gas when compared to 100ppm of CO, and CO sensitivity remains unaffected.

Figures 14 and 15 show data from tests conducted using interference gases listed in the UL2034 standard for Selectivity Test (Sec. 38) which are deemed to represent air contaminants likely to be found in the vicinity of an installed CO detector. Data for Figure 14 was collected by exposing samples in each of the test gases for a period of two hours as required by the UL standard. Sensor resistance at both the initial point and at the conclusion of test gas exposure was recorded. When compared to the sensor's measured resistance in 100ppm of CO (R_o), in all cases the resistance in test gas remained at more than 40 times that of resistance in 100ppm of CO, showing the sensor to have negligible influence by these gases.

Figure 15 demonstrates that sensor subjected to the interference gas tests do not change their characteristics after exposure to these gases. Samples subjected to the interference gas test were compared to reference samples (not subjected to the interference gas tests). Over a two week period, when not undergoing gas test, all samples were energized in fresh air under standard circuit conditions.

This data suggests that TGS2442 shows good durability against every gas used in GRI Test Protocol 1 and meets the requirements of UL2034.

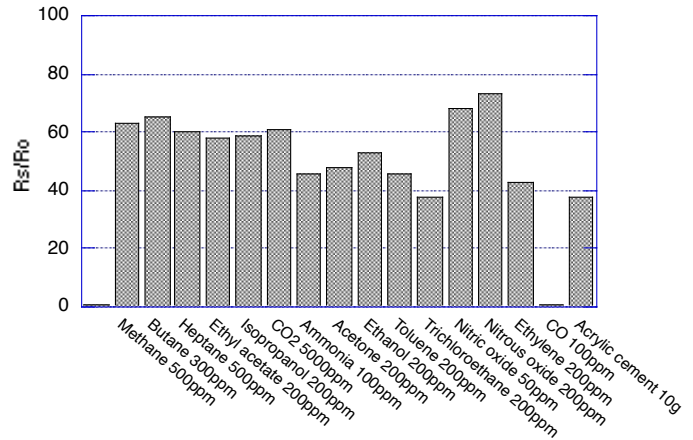

Fig. 13 - Effects of interference gases (GRI Test Protocol 1) ($R_o = R_s$ in CO 100ppm)

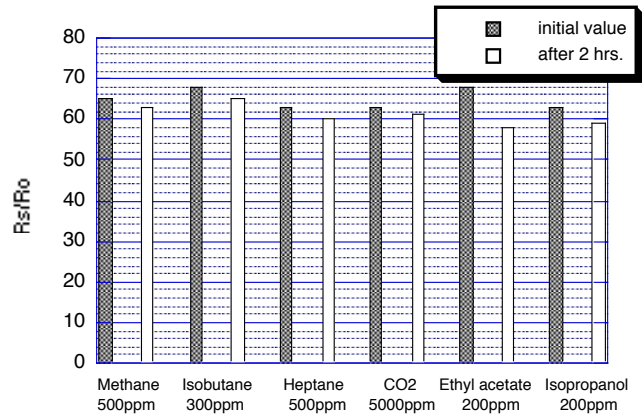

Figure 14 - Selectivity test (UL2034, Sec. 38) ($R_o = R_s$ in CO 100ppm)

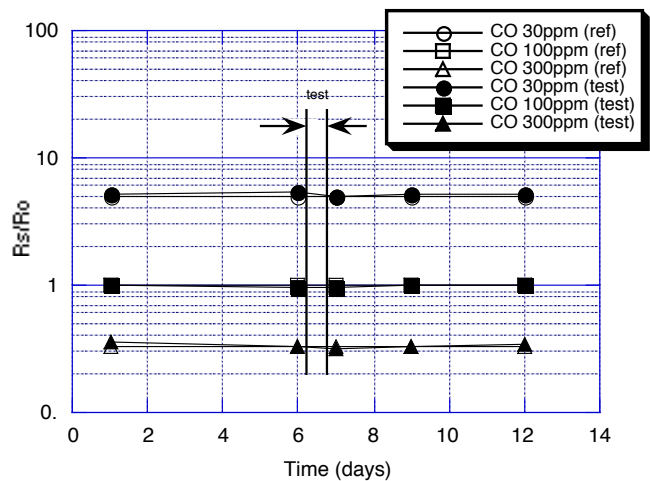

Figure 15 - Stability of sensors subjected to selectivity test ($R_o = R_s$ in CO 100ppm on Day 6)

4-2 Long-term stability

Figure 16 shows long-term stability data for TGS2442. Test samples were energized in normal air and under standard circuit conditions. Measurement for confirming sensor characteristics was conducted under standard test conditions (20°C, 65%RH). The initial value was measured after four days of energizing in normal air at the rated voltage. The Y-axis shows the ratio between measured sensor resistance and the initial (Day 4) resistance value, each in 100ppm of CO. Additional data will be published as it becomes available.

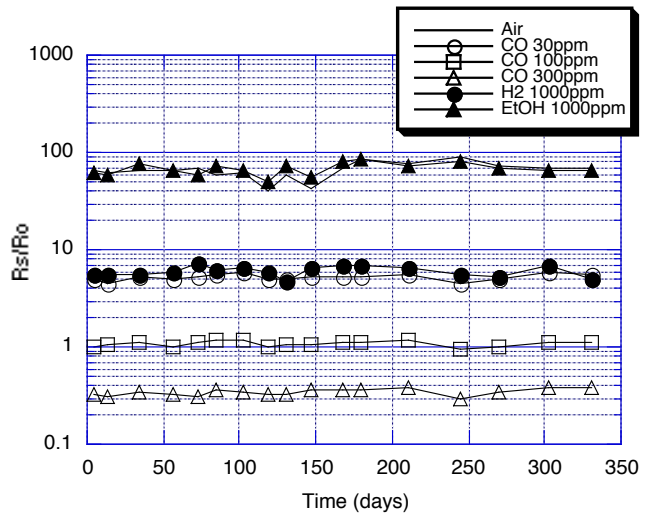

Figure 16 - Long term stability
(Ro = Rs in 100ppm of CO at Day 4)

4-3 Corrosion test

To demonstrate the durability of TGS2442 against corrosion, samples were subjected to test conditions called for by UL2034, Sec. 57-Corrosion Test. Over a three week period, a mixture of 100ppb of H2S, 20ppb of Cl2, and 200ppb of NO2 was supplied to the sensor at a rate sufficient to achieve an air exchange of 5 times per hour. When compared to reference samples not subjected to these corrosive gases, no significant difference can be noticed.

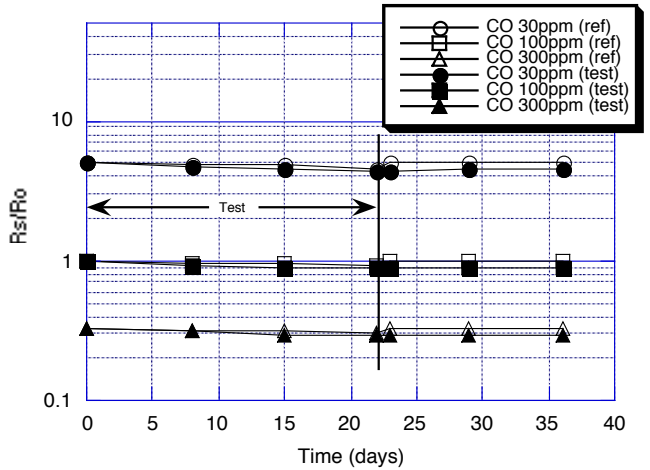

Figure 17 - Durability against corrosion
(Ro = Rs in 100ppm of CO at Day 2)

4-4 Variable ambient temperature test

To show the ability of TGS2442 to withstand the effects of high and low temperatures representative of shipping and storage, the sensor was subjected to the test conditions of UL2034 Sec. 44.2-Effect of Shipping and Storage. Unenergized test samples were subjected to 70°C for 24 hours, allowed to cool to room temperature for 1 hour, subjected to -40°C for 3 hours, and then allowed to warm up to room temperature for 3 hours. When compared to reference samples not subjected to these temperature extremes, no significant difference can be noticed.

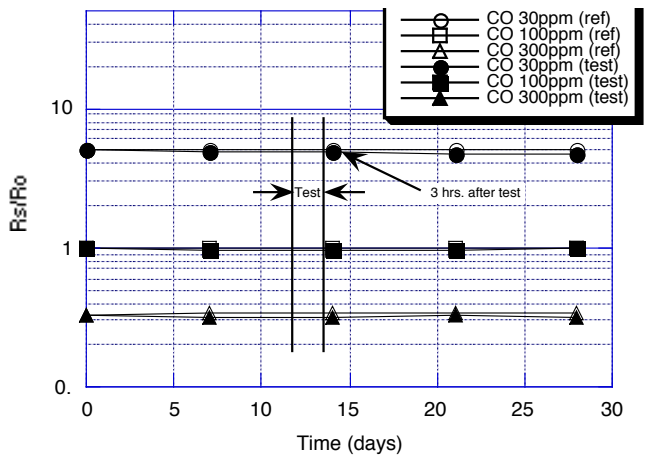

Figure 18 - Variable ambient temperature test
(Ro = Rs in 100ppm of CO at Day 0)

4-5 Humidity test

Figure 19 shows the comparison of reference sensors to those energized and exposed in an atmosphere of 52°C and 95% RH for a period of 168 hours, returned to normal air for 2 days, then followed by 168 hours in 20°C/10%RH as required by UL2034 Sec. 46A.1-Humidity Test. As the test measurements taken after the conclusion of the Humidity Test demonstrate, sensors subjected to the test show influence by humidity, but the sensor quickly returns to its normal value.

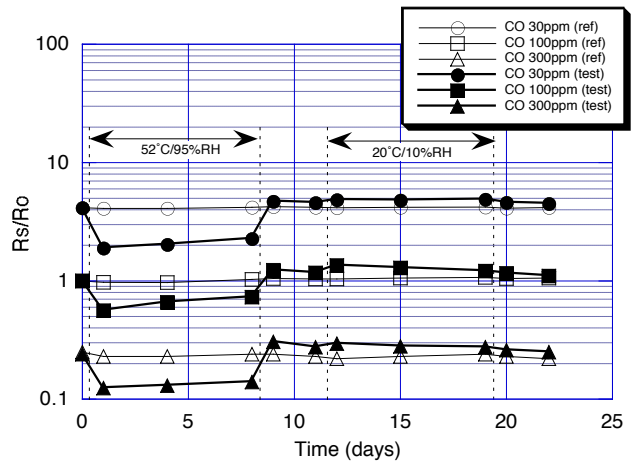

Figure 19 - Humidity test
(Ro = Rs in 100ppm of CO at Day 0)

4-6 Stability test

(1) False alarm test

To show the sensor's behavior under continuous low level exposure to CO, samples were tested against the procedure detailed in UL2034, Sec. 41.1(c)-Stability Test. Test samples were exposed to 30ppm continuously for a period of 30 days under standard circuit conditions. As this data demonstrates, false alarming does not occur as a result of continuous low level CO exposure.

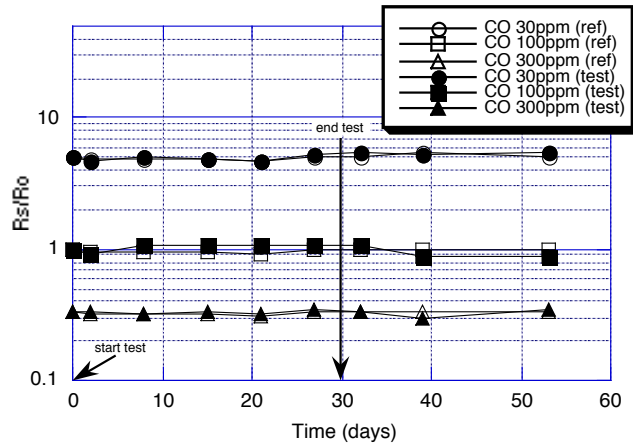

Figure 20 - False alarm test
(Ro = Rs in 100ppm of CO prior to test)

(2) Temperature cycle test

In accordance with UL2034, Sec. 41.1(e)-Stability Test, test samples were exposed to ten cycles (< 1 hr. and > 15 min.) of temperature from 0°C and 100%RH to 49°C and 40%RH. As the three test measurements taken after the conclusion of the test period demonstrate, sensors subjected to the test show negligible influence by temperature extremes.

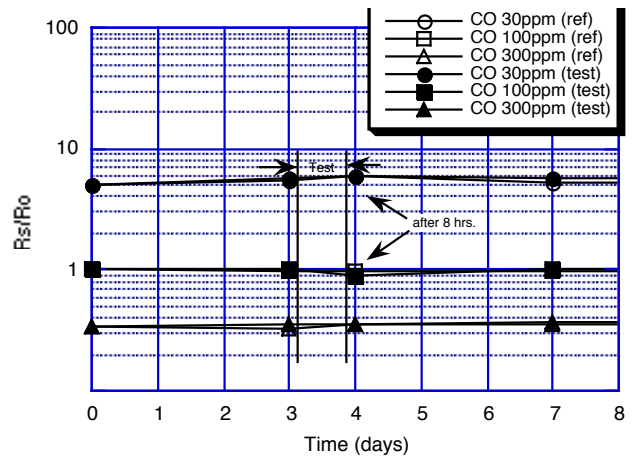

Figure 21 - Temperature cycle test
(Ro = Rs in 100ppm of CO prior to test)

5. Circuit Examples

5-1 Basic circuit including trouble detection

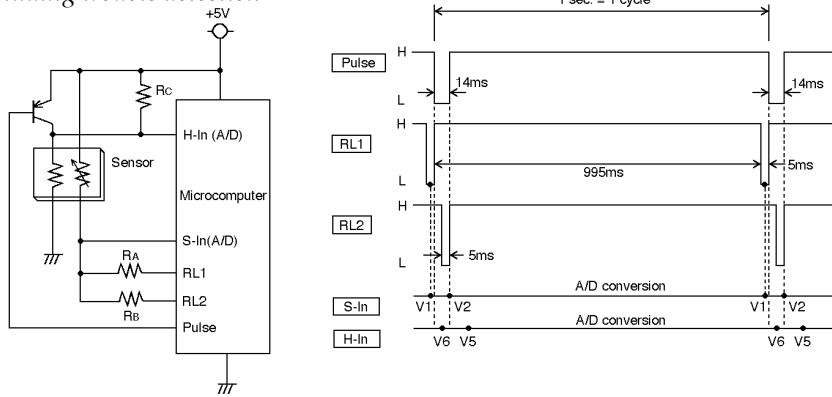

Figure 22 - Basic circuit (including trouble detection)

5-2 Calibration and temperature/humidity compensation

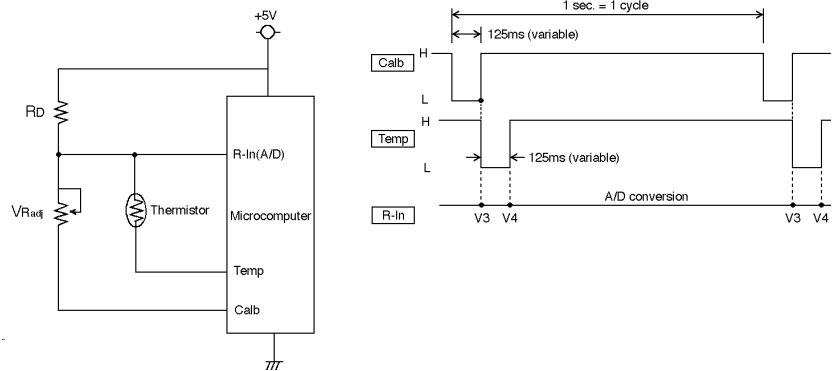

Figure 23 - Calibration & temperature compensation

S-In 8-bit A/D input port
 H-In 8-bit A/D input port
 R-In 8-bit A/D input port
 (Each of these ports acquires data at preset timing.)

RL1,RL2 open drain output port
 Pulse open drain output port
 Temp open drain output port
 Calb open drain output port

Circuit voltage (Vc) across the sensor is applied when RL1 or RL2 ports give the Low (L) output signal at preset timing.

V1 sampling voltage for gas detection
 V2 sampling voltage for sensor element trouble detection
 V3 sampling voltage for reference voltage
 V4 sampling voltage for temperature compensation
 V5,V6 sampling voltage for detecting heater circuit breakage

V1 and V2 are acquired during the last half of the 5msec Vc pulse (the first half of the Vc pulse is considered as the transient period). V5 is acquired during heater OFF, and V6 is acquired during heater ON pulse.

RA = 50% of Vc at the targeted gas concentration
 RB = 200-300kΩ RC = 10kΩ
 RD = 20kΩ RE = 10kΩ
 VRadj = 100kΩ

Thermistor: R (25°C) = 10kΩ, B constant = 3400

Sensor resistance (Rs):

$$R_s = \frac{5 - V1}{V1}$$

Calibration resistance (RCalb):

$$R_{Calb} = \frac{5 - V3}{V3}$$

Coefficient for temp. compensation (KTemp):

$$K_{Temp} = \frac{5 - V4}{V4}$$

Operation state:

State	Conditions
Normal	$R_s \times K_{Temp} > R_{Calb}$ and $V2 \geq 0.5V$
Alarm	$R_s \times K_{Temp} \leq R_{Calb}$ and $V2 \geq 0.5V$
Sensor malfunction	$V2 < 0.5V$
Heater malfunction	$V5 \geq 0.1V$ or $V6 \leq 4.5V$

Example of Application Circuit for TGS2442

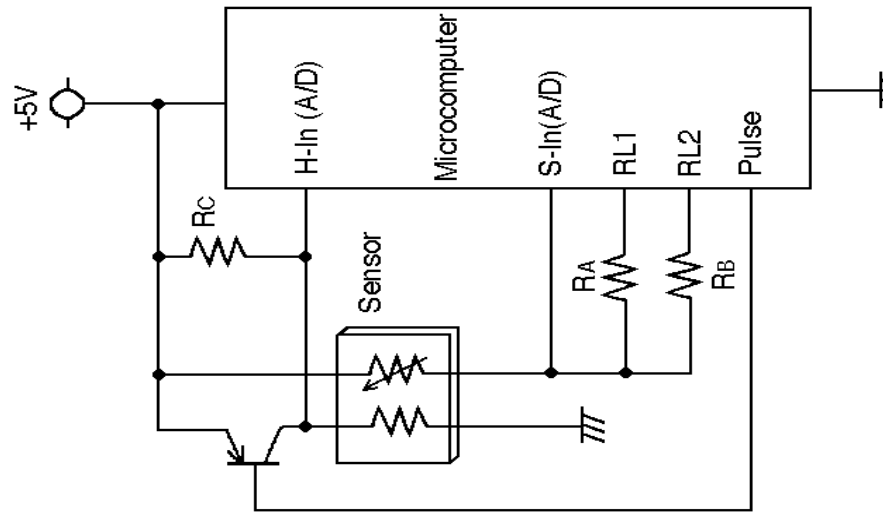
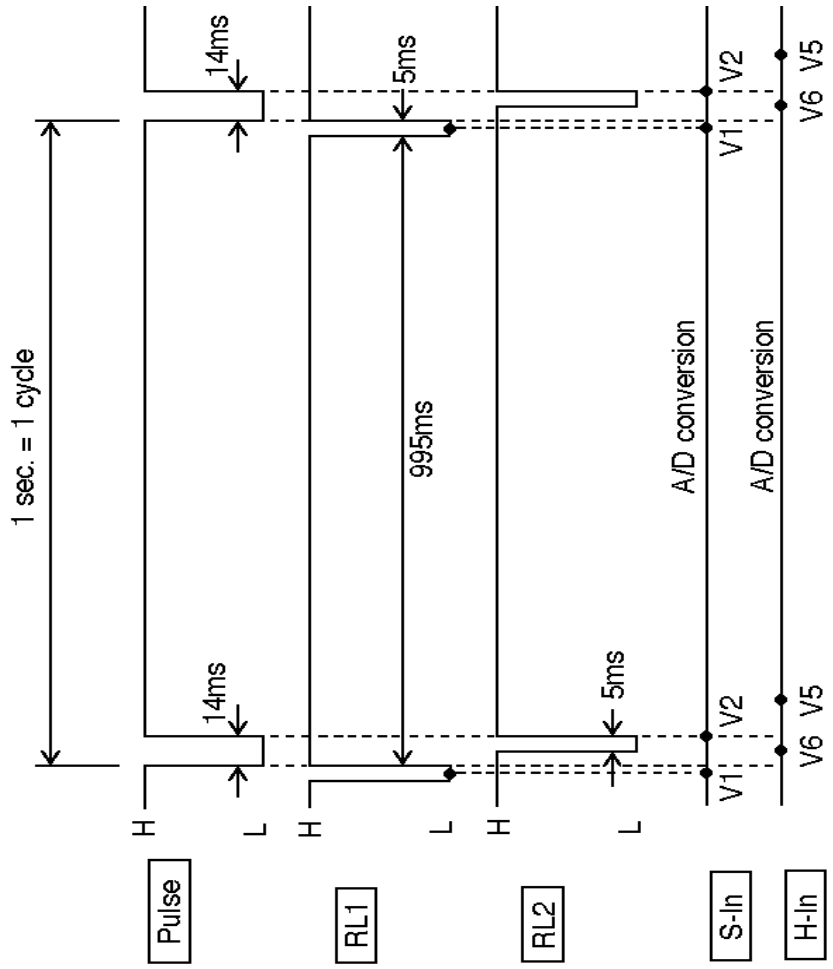

6. Marking and Packaging

6-1 Batch number

Rank and Lot. No. are indicated on the shrink wrap on the side of the sensor cap as shown in Figure 24.

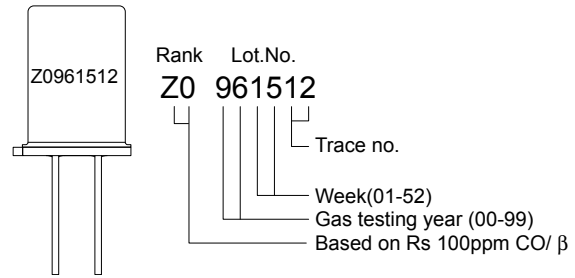

Figure 24 - Batch number coding

6-2 Packaging method (Fig. 25)

Fifty (50) pieces of sensor are packed in a plastic container, and five (5) containers are sealed inside a moistureproof aluminum coated bag. Several bags are then packed in a carton box (see Fig. 26).

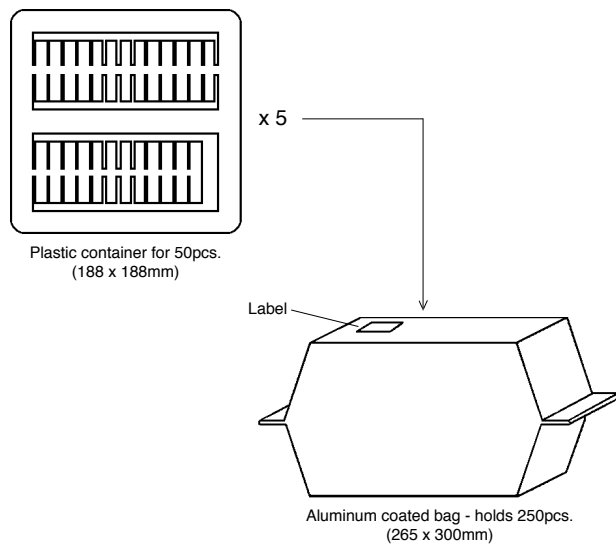

Figure 25 - Packing methodology

6-3 Label

A label showing product name, Rank and Lot No., quantity, and inspection date is affixed to the aluminum coated bag.

6-4 Handling instructions

It is recommended to begin sensor preheating within 24 hours after opening a sealed bag. Please keep unused sensors in a tightly sealed moistureproof bag.

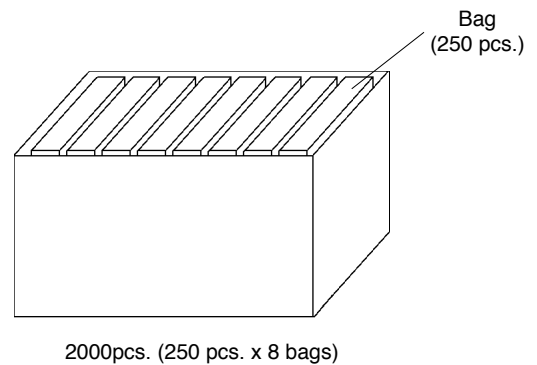

Figure 26 - Carton box

Figaro USA Inc. and the manufacturer, Figaro Engineering Inc. (together referred to as Figaro) reserve the right to make changes without notice to any products herein to improve reliability, functioning or design. Information contained in this document is believed to be reliable. However, Figaro does not assume any liability arising out of the application or use of any product or circuit described herein; neither does it convey any license under its patent rights, nor the rights of others.

Figaro's products are not authorized for use as critical components in life support applications wherein a failure or malfunction of the products may result in injury or threat to life.

FIGARO GROUP

HEAD OFFICE

Figaro Engineering Inc.
 1-5-11 Senba-nishi
 Mino, Osaka 562-8505 JAPAN
 Tel.: (81) 72-728-2561
 Fax: (81) 72-728-0467
 email: figaro@figaro.co.jp
 www.figaro.co.jp

OVERSEAS

Figaro USA Inc.
 3703 West Lake Ave. Suite 203
 Glenview, IL 60026 USA
 Tel.: (1) 847-832-1701
 Fax.: (1) 847-832-1705
 email: figarousa@figarosensor.com
 www.figarosensor.com